

CXJ-200/CXJ-400

DUAL-CELL CENTER GLAND EXPANSION JOINT

DESCRIPTION

The CXJ-200/CXJ-400 expansion joint system consists of an extruded, thermoplastic, dual gland expansion joint seals with integrated side flanges that are used to waterproof structural concrete expansion joints for positive-side below grade foundation walls and under structural slabs. The CXJ-200/CXJ-400 expansion joint system can be integrated with CETCO's waterproofing systems to create a true single source waterproofing system.

Movement at the joint is accommodated by the geometric shape of the double-cell, center gland configuration with two material layers to form the system. The center gland geometric shape is purpose-designed for low strain during movement, for optimal performance.

The unique double flange design of the CXJ-200/CXJ-400 facilitates multi-layered, watertight integration with the waterproofing system. A termination bar and anchors are installed on both sides of the center gland to mechanically secure both inside flanges of the CXJ-200/CXJ-400 to the concrete.

FEATURES

- High movement capability
- Dual-cell center gland provides redundant sealing
- Integrated dual side flanges provide integration with waterproofing membrane
- Factory-fabricated transition & termination components
- Heat welded seams for watertight connections

APPLICATION

The CXJ-200/CXJ-400 expansion joint system is designed for use at structural concrete expansion joints in below-grade foundations including backfilled walls, underslab, and blind-side shoring wall applications, such as soldier pile and lagging. The CXJ-200/CXJ-400 expansion joint system can be used for both hydrostatic and non-hydrostatic conditions.

BACKFILLED WALL INSTALLTION

When installing the CXJ-200/CXJ-400 expansion joint system in a backfilled foundation wall (positive-side), first insert the center gland of the CXJ-200/CXJ-400 expansion joint into the existing structural expansion joint to the depth where the narrow flanges are flush with the outside wall surface.

Next pull back one wide flange to expose the narrow flange and install a termination bar at the outside edge of the narrow flange.

Fasten term bar into the concrete with a threaded concrete anchor, 150 mm (6") on center, for the entire length of the expansion joint.

Repeat this termination bar installation procedure over the narrow flange on the other side of the expansion joint.

Pull back the wide flange, and trowel a continuous layer of BENTOSEAL (minimum 6 mm (1/4") thick) covering the entire narrow flange and termination bar.

Extend the BENTOSEAL application onto the concrete surface a minimum of 50 mm (2") past the width of the wide flange.

Install the waterproofing membrane between the narrow flange and wide flange embedded into the layer of BENTOSEAL.

Ensure that the waterproofing membrane is pressed firmly into the BENTOSEAL layer. Press the wide flange against the waterproofing membrane.

For VOLTEX & ULTRASEAL installations, start at the base of the CXJ-200/CXJ-400, install a second termination bar, fastened 300 mm (12") on center, along the edge of the wide flange, up to 300 mm (12") below finished grade. For COREFLEX installations, fully weld the wide flange of the CXJ to the yellow PVC side of the COREFLEX waterproofing membrane. Maintaining a minimum 12 mm (1/2") continuous weld.

Repeat this process on the other side of the CXJ-200/CXJ-400 expansion joint.

Once the installation has reached the height 300 mm (12") below finished grade fasten the termination bar every 150 mm (6") on center.

To complete the installation, install an entire sheet of waterproofing membrane (1 full width), stripped in along the entire length of the CXJ-200/CXJ-400 expansion joint system.

Tie into the adjacent waterproofing membrane according to the membrane installation guidelines. Insure that the entire installation is completed on the same day. Apply any protection course or drainage board as specified, prior to placement of backfill.



CXJ-200/CXJ-400 DUAL-CELL CENTER GLAND EXPANSION JOINT

PROPERTY LINE INSTALLATION

When applying the CXJ-200/CXJ-400 expansion joint system in a property line wall condition (application onto the shoring system to which concrete will be placed), mark the location of the structural expansion joint need.

Install a full roll width of waterproofing membrane centered over the expansion joint centerline, along the entire length of the expansion joint. Then apply a continuous layer of BENTOSEAL, onto the waterproofing membrane, extending laterally a minimum of 400 mm (16"). Then apply a 400 mm (16") wide by 6 mm (¼") thick continuous layer of BENTOSEAL on the waterproofing membrane, centered at the expansion joint.

For VOLTEX & ULTRASEAL installations, the joint can be temporarily held in place by fastening the CXJ-200/CXJ-400 expansion joint system at the edge of the wide flange. For COREFLEX installations DO NOT fasten through the waterproofing membrane.

Fully embed the CXJ-200/CXJ-400 expansion joint system, centered, into the continuous 6 mm (¼") thick BENTOSEAL layer.

Take care to install the CXJ-200/CXJ-400 expansion joint system so that it spans the centerline of the structural expansion joint equally.

Next install a vertical strip of waterproofing membrane along both sides of the CXJ-200/CXJ-400 expansion joint system.

For VOLTEX & ULTRASEAL installations, the waterproofing membrane should be installed between the BENTOSEAL along the exterior edge of the narrow flange, and fasten, 100 mm (4") on center with manufacturer provided 100 mm (4") shoring anchors through the entire CXJ-200/CXJ-400 expansion joint system and waterproofing assembly securing the assembly to the shoring system

For COREFLEX installations, the waterproofing membrane should be installed between

the BENTOSEAL along the exterior edge of the narrow flange, and fully weld the narrow flange of the CXJ to the black PVC side of the COREFLEX waterproofing membrane.

ADDITIONAL CONSIDERATIONS

Only straight butt welds of the CXJ-200/CXJ-400 expansion joint system are allowed at the job site, and must be performed by a CETCO Approved Applicator to qualify for the manufacturer's warranty eligibility. Welding of in-line segments must be performed per manufacturer's guidelines using all the proper tools - including the CXJ WELD KIT when applicable.

CXJ PATCH SHEETS are used to fabricate rubber splicing strips a minimum 25 mm (1") wide that should be welded over all in-line gland weld seams to reinforce the field weld at the joined segments.

Corners and transitions (angle changes, tees, crosses, etc.) must be measured and submitted to CETCO for fabrication to be eligible for warranty consideration. Only factory-fabricated corners and transitions are accepted for installation and eligible for manufacturer's warranty.

At the top of the foundation wall, the CXJ-200/CXJ-400 expansion joint system installation will typically transition from vertical to horizontal; extending across the top surface crete wall.

Then it will turn up a minimum of 150 mm (6") (to the height required to meet the building design and local building codes) at the location of the moisture/air barrier plane then transition to an above-grade expansion joint system provided by Others per the building design.

Install CXJ-200/CXJ-400 expansion joint system in accordance with manufacturer's guidelines and details to meet the specific project building wall design. Contact CETCO for application and installation information not contained herein.

MOVEMENT CAPABILITY

The CXJ-200 expansion joint system can be installed into joints ranging from 50 mm to 75 mm (2" to 3") wide.

Movement capability of the 50 mm (2") nominal center gland width is ± 31 mm (1 ¼"); thereby CXJ-200 gland can compress to 18 mm (¾") and expand to 81 mm (3 ¼") in service.

The CXJ-400 expansion joint system can be installed into joints ranging from 75 mm to 125 mm (3" to 5") wide.

Movement capability of the 100 mm (4") nominal center gland width is plus or minus 62 mm (2 ½"); thereby CXJ-400 gland can compress to 37 mm (1 ½") and expand to 162 mm (6 ½") in service

CXJ-200/CXJ-400 DUAL-CELL CENTER GLAND EXPANSION JOINT

SIZING

The CXJ-200 Expansion joint is a 50 mm (2") wide center gland expansion joint product and the CXJ-400 Expansion joint is 100 mm (4") wide center gland expansion joint. Lengths are custom manufactured to actual project dimensions as measured and submitted by the contractor.

Transition corner angles are custom manufactured and require field measurement to be submitted by the contractor.

For additional information please contact your local CETCO representative to assist with ordering of all necessary CXJ-200/CXJ-400 Expansion joint components.

ACCESSORIES

For warranty eligibility all transition components and terminations must be factory produced. Preformed components are butt welded onto straight segments of the CXJ-200/400 Expansion Joint in the field. Please speak with your local CETCO representative your job need requires a custom transition/termination component to discuss pricing and necessary lead times.

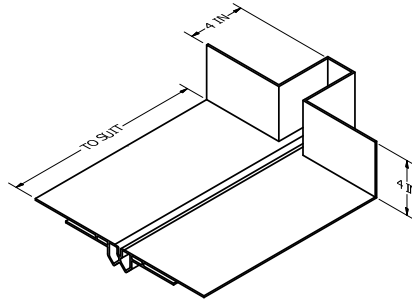

Boot Termination

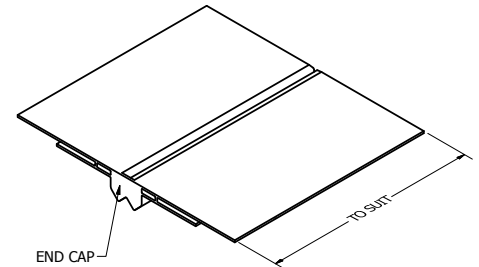

Welded End Cap

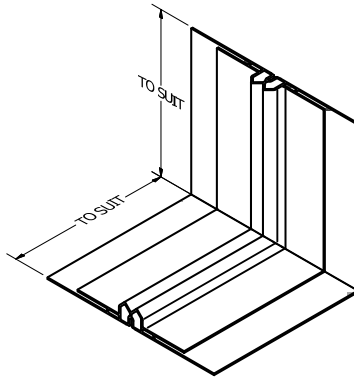

90 Degree Vertical Transition

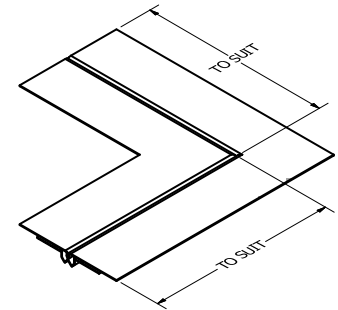

90 Degree Horizontal Transition

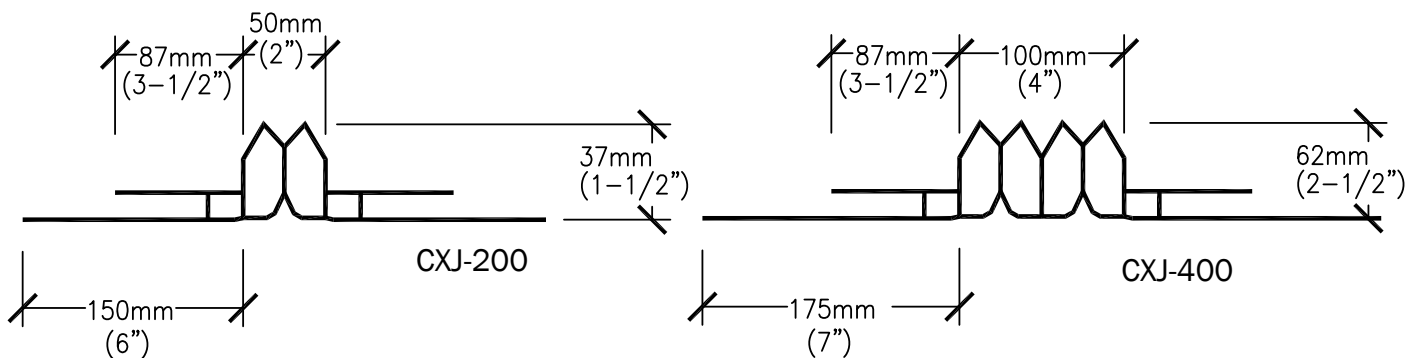

NOTE: ALL DIMENSIONS ARE $\pm 3\text{mm}$ ($1/8''$)

North America: 847.851.1800 | 800.527.9948 | www.cetco.com

UPDATED: JANUARY 2020

© 2017 Minerals Technologies Inc. IMPORTANT: The information contained herein supersedes all previous printed versions, and is believed to be accurate and reliable. For the most up-to-date information, please visit www.cetco.com. CETCO accepts no responsibility for the results obtained through application of this product. All products are sold on the understanding that the user is solely responsible for determining their suitability for the intended use and for proper use and disposal of the product. CETCO MAKES NO WARRANTY OF MERCHANTABILITY OR SUITABILITY FOR ANY PARTICULAR PURPOSE IN CONNECTION WITH ANY SALE OF THE PRODUCTS DESCRIBED HEREIN. CETCO reserves the right to update information without notice.

